

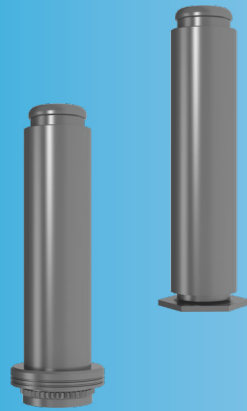

PEM eConnect™ fastening
technology provides superior
electrical connection solutions



EC™

**PEM eConnect™
FASTENERS**

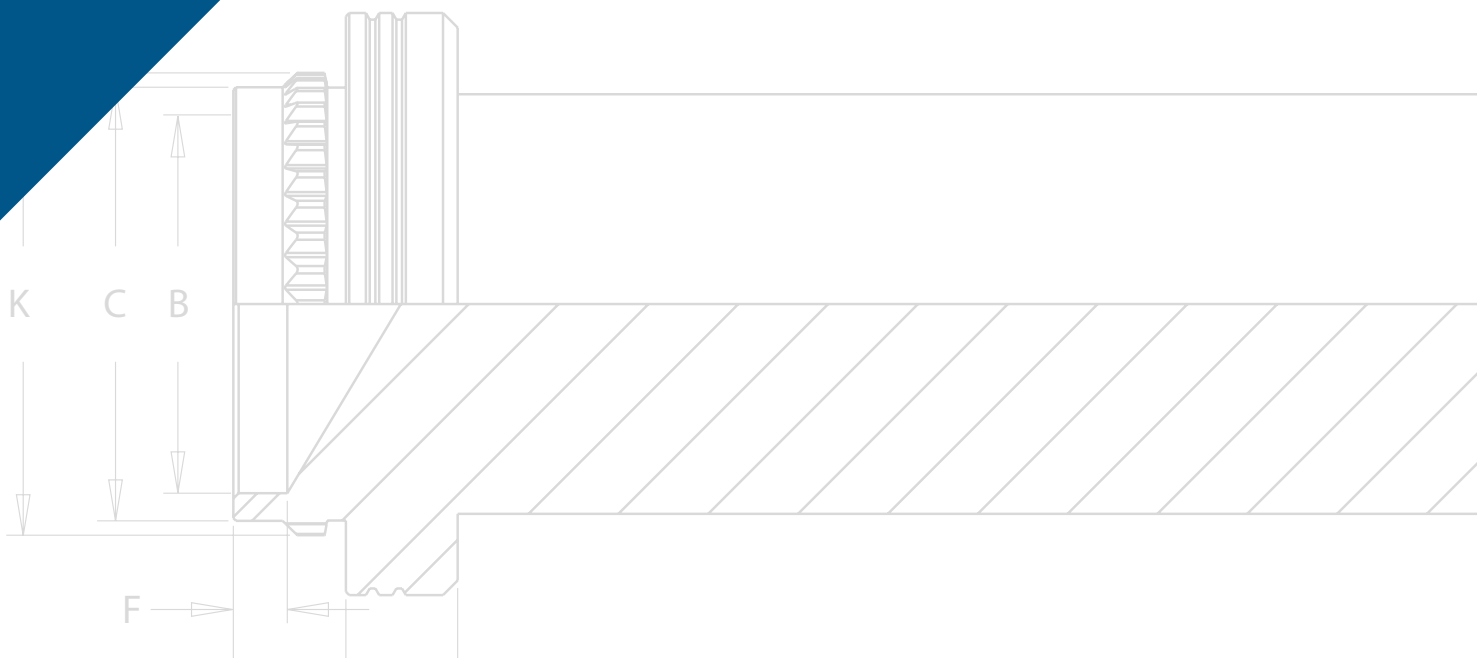

PEM ECONNECT™ PIN FASTENING TECHNOLOGY

PEM eConnect™ current carrying pins provide superior electrical connections in applications that demand superior performance from internal components.

- Joint has an electrical resistance of less than 100 $\mu\Omega$. No hot spots or poor conductivity
- Available in self clinching and broaching mounting styles
- Fully automated installation systems available for an efficient, cost-savings total system solution

EPCRB™ PEM eConnect™ Self-Clinching Pin

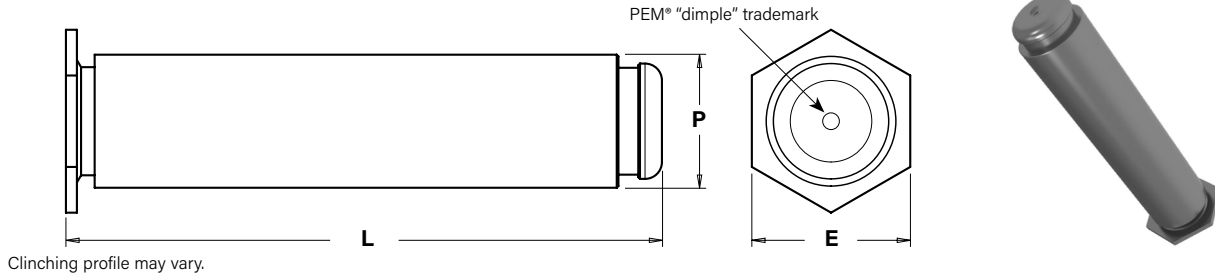

Type	Pin Dia. Code	Pin Length Code	Sheet Thickness		Hole Size in Sheet +.002" / +0.05mm		E Nom.		L ±.002" / ± 0.05mm		P ±.004" / ±0.1mm		Min. Dist. Hole C/L to Edge ⁽¹⁾	
			in.	mm	in.	mm	in.	mm	in.	mm	in.	mm	in.	mm
EPCRB	8	35.6	.079 - .158	2 - 4	.389	8.1	.375	9.53	1.402	35.6	.315	8	.374	9.5

(1) For more information on proximity to bends and distance to other clinch hardware, see [PEM® Tech Sheet C/L To Edge](#).

PART NUMBER DESIGNATION

EPCR B - 8 - 35.6 Ag

↓ ↓ ↓ ↓ ↓

Type Material Pin Pin Finish
Code Diameter Length

EPFRB™ PEM eConnect™ Broaching Pin

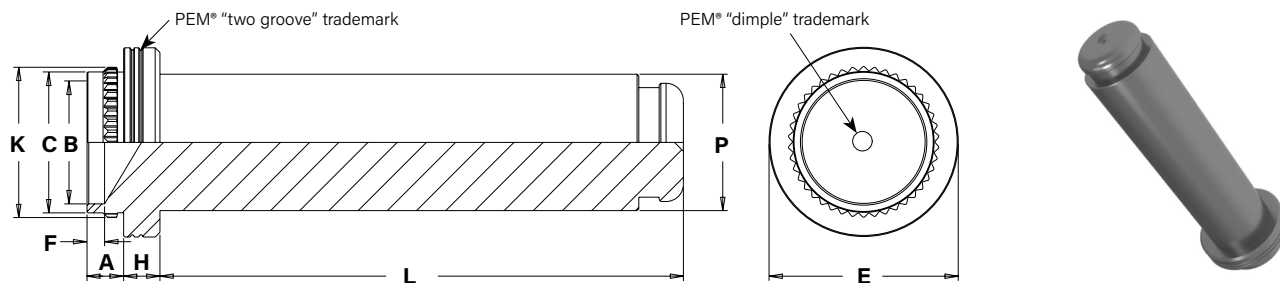

Type	Pin Dia. Code	Pin Length Code	Sheet Thickness		Hole Size in Sheet +.002" / +0.05mm		A Max.		B ±.003" / ±0.08mm		C Max.		E ±.005" / ±0.13mm		F ±.010" / ±0.25mm		H ±.0029" / ±0.07mm		K ±.003" / ±0.08mm		L ±.007" / ±0.18mm		P ±.002" / ±0.05mm		Min. Dist. Hole C/L to Edge ⁽¹⁾ +.005"/-.001" +.013/-0.03mm	
			in.	mm	in.	mm	in.	mm	in.	mm	in.	mm	in.	mm	in.	mm	in.	mm	in.	mm	in.	mm	in.	mm	in.	mm
EPFRB	8	30.8	.049-.065	1.24-1.65	.335	8.5	.058	2.18	.284	7.21	.329	8.35	.437	11.09	.037	0.93	.084	2.13	.350	8.89	1.209	30.8	.315	8	.346	8.8

(1) For more information on proximity to bends and distance to other clinch hardware, see [PEM® Tech Sheet C/L To Edge](#).

PART NUMBER DESIGNATION

EPFR B - 8 - 30.8 Ag

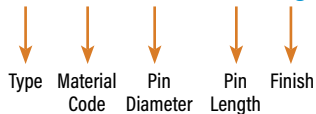

MATERIAL AND FINISH SPECIFICATIONS

Type	Component Material	Standard Finishes	For Use In	
	Free Machining Brass	Matte Electroplated Silver per ASTM B700, Type II, Grade A ⁽²⁾	Sheet Hardness HRB 44 / HB 80 or less ⁽³⁾	PC Board
EPCRB	▪	▪	▪	
EPFRB	▪	▪		▪
Part Number Code for Finishes		Ag		

(2) See PEM [Technical Support](#) section of our web site for related plating standards and specifications.

(3) HRB - Hardness Rockwell "B" Scale. HB - Hardness Brinell.

INSTALLATION

EPCRB™ Self-clinching Pin

1. Prepare properly sized mounting hole in sheet. Do not perform any secondary operations such as deburring.
2. Insert pin through mounting hole (punch side) of sheet and into anvil hole.
3. With punch and anvil surfaces parallel, apply squeezing force to embed the head of the pin flush in the sheet.

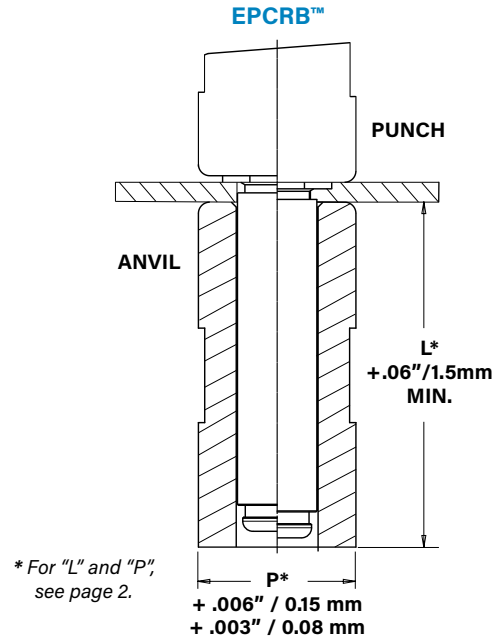

EPFRB™ Broaching Pin

1. Prepare properly sized mounting hole in board.
2. Place fastener into the anvil hole and place the mounting hole over the shank of the fastener.
3. Using a punch flaring tool and a recessed anvil, apply squeezing force until the shoulder of the fastener contacts the board. As the fastener seats itself in the proper position, the punch tool will flare the extended portion of the shank outward to complete the installation. The combination of broaching and flaring provides high pushout performance.

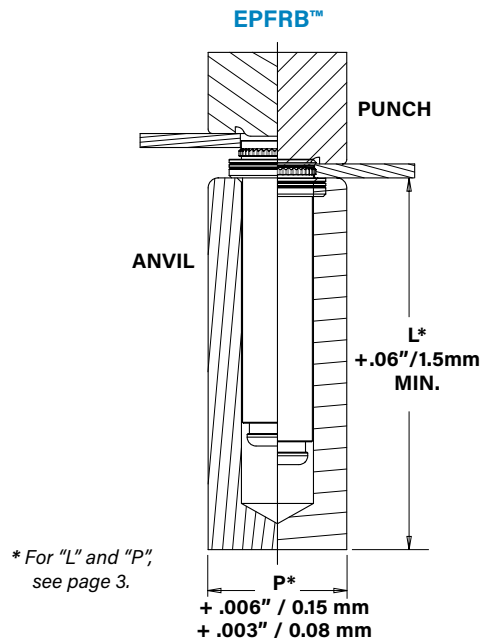

Installation Tooling

UNIFIED	Type	HAEGER® Part Number		PEMSERTER® Part Number	
		Anvil	Punch	Anvil	Punch
	EPCRB	158751	H1080020L	8026712	975200048
	EPFRB	158751	158752	8026712	8026681

Installation Notes

- For best results we recommend using a HAEGER® or PEMSERTER® machine for installation of PEM® self-clinching fasteners. See our [website](#) for more information.
- Visit the [Animation Library](#) on our website to view the installation process.

For Additional HAEGER® and PEMSERTER® Tooling Information / Part Numbers

The diagram illustrates the digital tooling resources available for Haeger and Pemsertor machines. On the left is a red Haeger 824 machine. In the center, a laptop displays the Haeger website with a 'Tooling' dropdown menu showing options: Auto Tooling Wizard, Manual Tooling Wizard, Force Chart, BTM Tooling, and Manual Tooling Catalog. Below the laptop, text reads: 'Go to haeger.com to access the Auto and Manual Tooling Wizards'. On the right is a blue Pemsertor machine. Below it, text reads: 'Or download the HAEGER WIZZARD Phone App'. A smartphone displays the app interface with a 'Tooling Wizard' button and a list of options: BTM Tooling, Force Chart, Machine Selection, Machine Specification, Request RMA, and myHaeger. A circular callout for the app shows 'OneTouch 4e XYZ-R' and 'Tooling Wizard' and 'BTM Tooling' options. At the bottom of the diagram are four orange buttons: 'HAEGER® MANUAL TOOLING CATALOG', 'HAEGER® AUTO TOOLING CATALOG', 'PEMSERTER® MANUAL TOOLING CATALOG', and 'PEMSERTER® AUTO TOOLING CATALOG'.

PERFORMANCE DATA⁽¹⁾

Type	Test Sheet Material							
	C110 Copper HRB 44				FR-4 Fiberglass			
	Installation		Pushout		Installation		Pushout	
	(lbs.)	(kN)	(lbs.)	(kN)	(lbs.)	(kN)	(lbs.)	(N)
EPCRB	5845	26	900	4	—	—	—	—
EPFRB	—	—	—	—	1710	76	169	750

(1) Published installation forces are for general reference. Actual set-up and confirmation of complete installation should be made by observing proper seating of fastener as described in the installation steps. Other performance values reported are averages when all proper installation parameters and procedures are followed. Variations in mounting hole size, sheet material, and installation procedure may affect performance. Performance testing this product in your application is recommended. We will be happy to provide technical assistance and/or samples for this purpose.

EPCRB™ Derating Curve

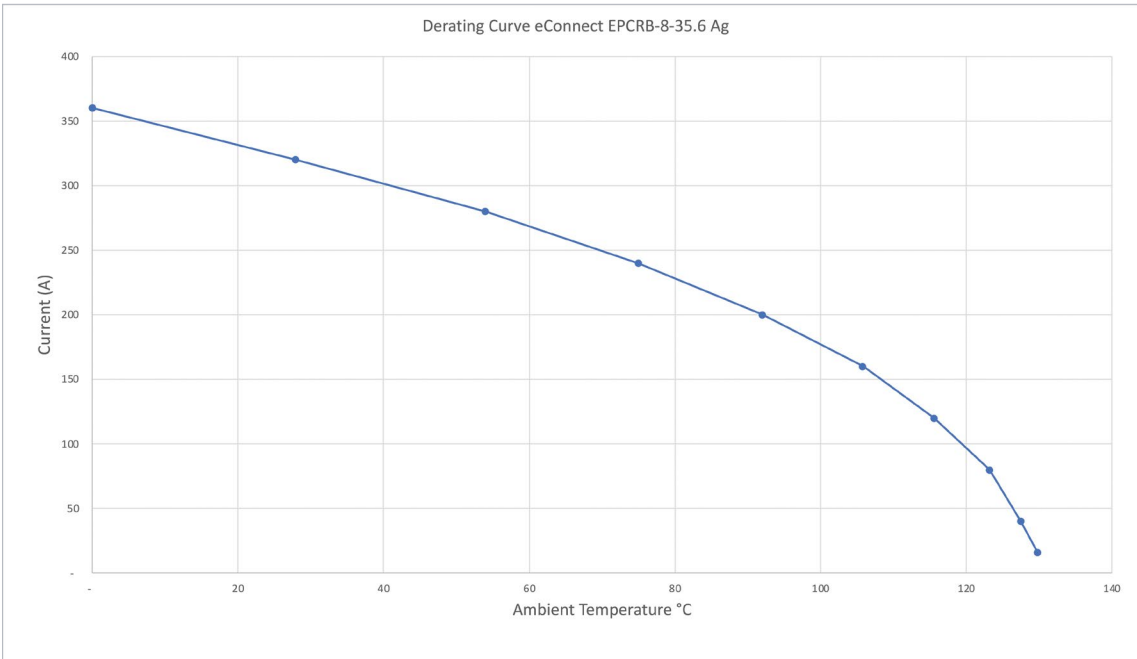

EPFRB™ Derating Curve

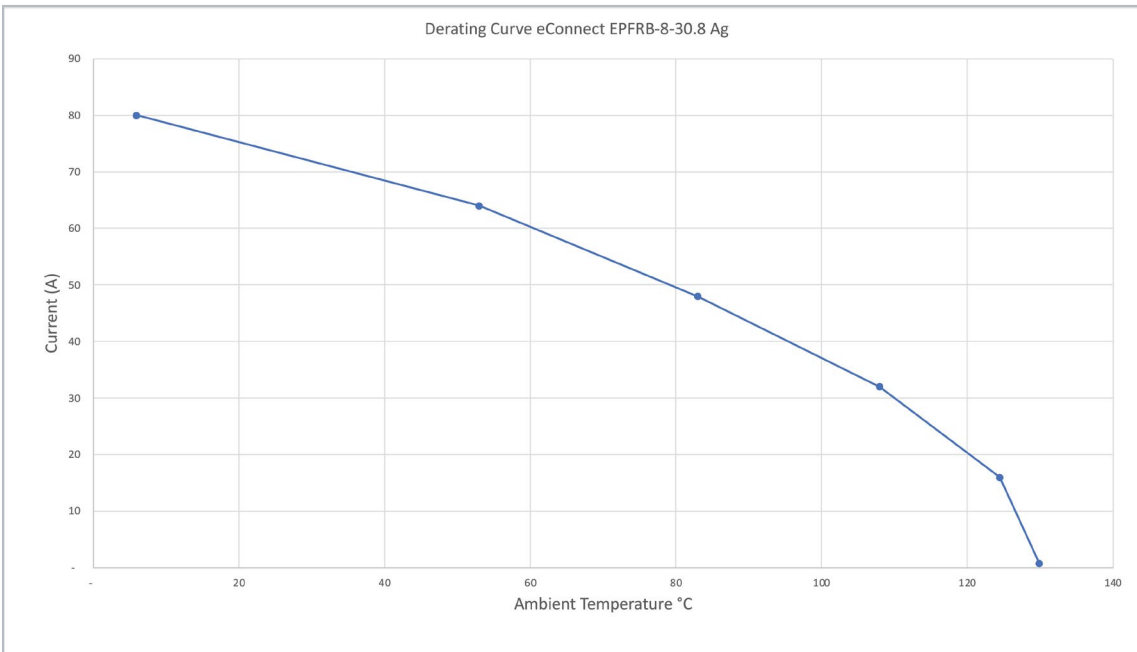

All PEM® products meet our stringent quality standards. If you require additional industry or other specific [quality certifications](#), special procedures and/or part numbers are required. Please contact your local sales office or representative for further information.

Regulatory [compliance information](#) is available in Technical Support section of our website. Specifications subject to change without notice. See our website for the most current version of this bulletin.

PennEngineering®



North America: Danboro, Pennsylvania USA ■ E-mail: info@pemnet.com ■ Tel: +1-215-766-8853 ■ 800-237-4736 (USA)

Europe: Galway, Ireland ■ E-mail: europa@pemnet.com ■ Tel: +353-91-751714

Asia/Pacific: Singapore ■ E-mail: singapore@pemnet.com ■ Tel: +65-6-745-0660

Shanghai, China ■ E-mail: china@pemnet.com ■ Tel: +86-21-5868-3688

Visit our PEMNET™ Resource Center at www.pemnet.com ■ Technical support e-mail: techsupport@pemnet.com